

Natural Air 350

Mechanical ventilation with heat recovery

Ideal for 4 to 5 bedroom properties, the Natural Air 350 Mechanical Ventilation with Heat Recovery (MVHR) unit provides whole-house ventilation - supplying and extracting air through the entire property. Fresh air is supplied from outside the premises, while warm, stale, damp air is continuously extracted out.

Natural Air 350 units offer efficient, balanced ventilation that produces healthy indoor air quality while saving energy with its efficient EC ball-bearing motor. Meanwhile, ultra-fine G4 filters ensure a pollutant-free environment that's literally a breath of fresh air for allergy sufferers. You'll also enjoy a comfortable temperature without annoying draughts or cold spots thanks to the unit's 100% summer bypass and winter defrost functions - so no matter what the weather's doing outside, everything will feel 'just right' inside. NA350 is SAP Appendix Q listed.



Key Features

- Clever humidity control: Unique, active humidistat reacts in real-time to gradual increases in humidity - ideal for even the smallest wetroom
- Hassle-free maintenance: Fast, simple access to fans, filters and heat exchange
- Datalogger: The Natural Air 350 has an integral datalogger, recording its daily use
- Silent nights and days: Sound absorbing EPP material dampens noise. Direct airflow path minimises internal pressure drop resulting in whisper-quiet operation
- Low Specific Fan Power: Smooth pressure drop thanks to energy efficient heat exchanger, G4 filter and unit specific fan configuration
- Constant Volume for life: The Natural Air 350 uses Intelligent Adaptiflow sensing to deliver constant volume performance (applies to model 066992 only)

| | Natural Air 350 | Natural Air 350 PH |
|---|---------------------|-----------------------------------|
| Reference Number | 066978 | 066992 |
| Motor Type | Backward Curved EC | Forward Curved Constant Volume EC |
| Speeds | trickle/boost/purge | trickle/boost/purge |
| Maximum Extract Performance (FID, m³/h) | 360 | 350 |
| Maximum Extract Performance (m³/h @100Pa) | 350 | 330 |
| Maximum Extract Performance (FID, l/s) | 100 | 100 |
| Maximum Extract Performance (l/s @100Pa) | 97 | 97 |
| Maximum Fan Power (W) | 151 | 215 |
| Spigot Diameter (mm) | 150, 160, 190 & 200 | 150, 160, 190 & 200 |
| Weight (Kg) | 35.2 | 35.2 |
| Approvals / Listing | CE/SAP Appendix Q | CE/Passivhaus |
| UK Guarantee (years) | 2 | 2 |

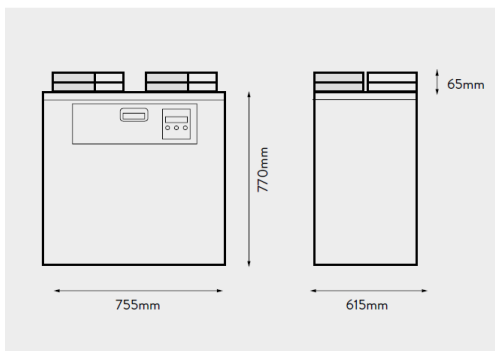

| Performance | | | | |
|---------------|--------------------|-------------------|--------------------|-------------------|
| K+n wet rooms | SFP (W/l/s) [2009] | Efficiency [2009] | SFP (W/l/s) [2012] | Efficiency [2012] |
| n = 1 | - | - | 0.40 | 90% |
| n = 2 | 0.37 | 90% | 0.43 | 89% |
| n = 3 | 0.38 | 89% | 0.49 | 88% |
| n = 4 | 0.44 | 88% | 0.61 | 87% |
| n = 5 | 0.51 | 87% | 0.75 | 86% |
| n = 6 | 0.59 | 87% | 0.93 | 86% |
| n = 7 | 0.70 | 86% | 1.16 | 85% |